



MUGNAINI STYLE: XE 450
 FORMAX STYLE: GE, 450, -45/+45, ST
 FORMAX CODE: FGE 103 ST

REINFORCING FIBRE SPECIFICATION

FIBRE TYPE: E-GLASS ROVINGS
 AREAL WEIGHT: 443 GSM ($\pm 5\%$)
 SIZE COMPATABILITY: POLYESTER / VINYLESTER / EPOXY
 FIBRE SPECIFICATIONS: 300TEX & 68TEX
 WIDTH: 1270MM (± 5 MM)

STITCHING FIBRE SPECIFICATION

STITCHING THREAD: 780TEX TEXTURED POLYESTER
 STITCHING GAUGE: 6 GG OR 2.36 ENDS/CM
 STITCH LENGTH: 2.50MM
 STITCH TYPE: PILLAR
 STITCH WEIGHT: 7GSM

PLY CONSTRUCTIONS

0° SUPPORT THREAD
 FIBRE SPECIFICATION E-GLASS YARN
 FIBRE TEX: 68TEX
 GAUGE: 0.5
 PLY WEIGHT 1.5GSM

-45° PLY
 FIBRE SPECIFICATION E-GLASS
 FIBRE TEX 300TEX
 GAUGE: 13
 PLY WEIGHT 216GSM

90° SUPPORT THREAD
 FIBRE SPECIFICATION E-GLASS YARN
 FIBRE TEX 68TEX
 GAUGE 0.5
 PLY WEIGHT 1.5GSM

+45° PLY
 FIBRE SPECIFICATION E-GLASS
 FIBRE TEX 300TEX
 GAUGE 13
 PLY WEIGHT 216GSM

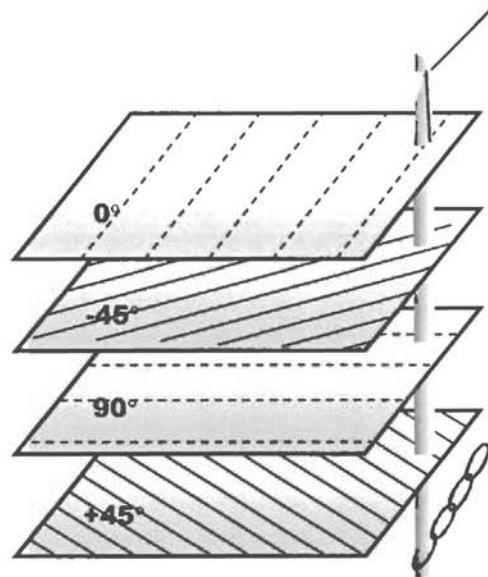

MATERIAL PROPERTIES	-45° DIRECTION	+45° DIRECTION
FIBRE CONTENT (%)	-	-
FLEXURAL STRENGTH (N/MM ²)	-	-
FLEXURAL MODULUS (KN/MM ²)	-	-
TENSILE STRENGTH (N/MM ²)	-	-

This information is for design evaluation only. While it is believed to be correct, it is not guaranteed in any way. Formax stresses that it is the user that shall determine the suitability of a product for its end-use, and the user that assumes all liability in connection therewith.

Distribuito da:
 Mugnaini Group Srl - Via delle Cannelle Z.I. di Montranito - 55040 Stiava - Massarosa (LU)
 Tel. 0584 962344 - Fax 0584 940578 - info@mugnaini.it - www.mugnaini.it