



MUGNAINI STYLE: QE 600  
 FORMAX STYLE: GE, 600, 0/-45/90/+45  
 FORMAX CODE: FGE 109

**REINFORCING FIBRE SPECIFICATION**

FIBRE TYPES: E-GLASS  
 CALCULATED AREAL WEIGHT: 625GSM (±5%)  
 SIZE COMPATABILITY: POLYESTER / EPOXY / VINYLESTER  
 FIBRE SPECIFICATIONS: 600TEX, 300TEX  
 WIDTH: 1270MM

**STITCHING FIBRE SPECIFICATION**

STITCHING THREAD: 78DTEX TEXTURED POLYESTER  
 STITCHING GAUGE: 6 GG  
 STITCH LENGTH: 2.20 MM  
 STITCH TYPE: PILLAR-TRICOT  
 STITCH WEIGHT: 7 GSM

**PLY CONSTRUCTION**

**0° PLY**  
 FIBRE SPECIFICATION E-GLASS  
 FIBRE TEX: 600TEX  
 GAUGE: 6 GG  
 PLY WEIGHT 142GSM

**-45° PLY**  
 FIBRE SPECIFICATION E-GLASS  
 FIBRE TEX 300TEX  
 GAUGE: 10 GG  
 PLY WEIGHT 167GSM

**90° PLY**  
 FIBRE SPECIFICATION E-GLASS  
 FIBRE TEX 300TEX  
 GAUGE: 12 GG  
 PLY WEIGHT 142GSM

**+45° PLY**  
 FIBRE SPECIFICATION E-GLASS  
 FIBRE TEX 300TEX  
 GAUGE: 10 GG  
 PLY WEIGHT 167GSM

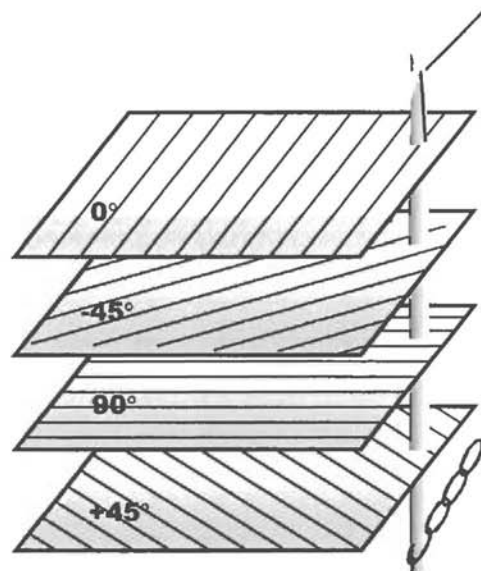

MATERIAL PROPERTIES	0° DIRECTION	-45° DIRECTION	90° DIRECTION	+45° DIRECTION
GLASS CONTENT (%)				
FLEXURAL STRENGTH (N/MM <sup>2</sup> )				
FLEXURAL MODULUS (KN/MM <sup>2</sup> )				
TENSILE STRENGTH (N/MM <sup>2</sup> )				

This information is for design evaluation only. While it is believed to be correct, it is not guaranteed in any way. Formax stresses that it is the user that shall determine the suitability of a product for its end-use and the user that assumes all liability in connection therewith

Distribuito da:  
 Mugnaini Group Srl - Via delle Cannelle Z.I. di Montranito - 55040 Stiava - Massarosa (LU)  
 Tel. 0584 962344 - Fax 0584 940578 - info@mugnaini.it - www.mugnaini.it