



MUGNAINI STYLE: QE 1200
 FORMAX STYLE: GE, 1200, 0/-45/90/+45
 FORMAX CODE: FGE 112

REINFORCING FIBRE SPECIFICATION

FIBRE TYPES: E-GLASS
 CALCULATED AREAL WEIGHT: 1173GSM (±5%)
 SIZE COMPATIBILITY: POLYESTER / EPOXY / VINYLESTER
 FIBRE SPECIFICATIONS: 1200TEX, 600TEX
 WIDTH: 1270MM

STITCHING FIBRE SPECIFICATION

STITCHING THREAD: 78DTEX TEXTURED POLYESTER
 STITCHING GAUGE: 6 GG
 STITCH LENGTH: 2.50MM
 STITCH TYPE: PILLAR / TRICOT
 STITCH WEIGHT: 7 GSM

PLY CONSTRUCTION

0° PLY
 FIBRE SPECIFICATION E-GLASS
 FIBRE TEX: 1200TEX
 GAUGE: 6 GG
 PLY WEIGHT 283GSM

-45° PLY
 FIBRE SPECIFICATION E-GLASS
 FIBRE TEX 600TEX
 GAUGE: 9 GG
 PLY WEIGHT 300GSM

90° PLY
 FIBRE SPECIFICATION E-GLASS
 FIBRE TEX 600TEX
 GAUGE: 12 GG
 PLY WEIGHT 283GSM

+45° PLY
 FIBRE SPECIFICATION E-GLASS
 FIBRE TEX 600TEX
 GAUGE: 9 GG
 PLY WEIGHT 300GSM

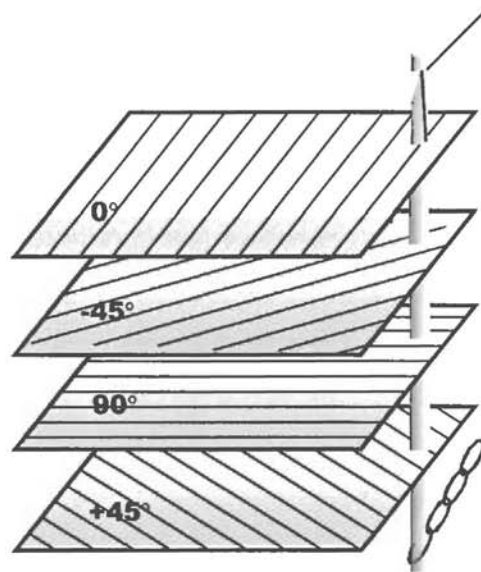

MATERIAL PROPERTIES	0° DIRECTION	-45° DIRECTION	90° DIRECTION	+45° DIRECTION
GLASS CONTENT (%)				
FLEXURAL STRENGTH (N/MM ²)				
FLEXURAL MODULUS (KN/MM ²)				
TENSILE STRENGTH (N/MM ²)				

This information is for design evaluation only. While it is believed to be correct, it is not guaranteed in any way. Formax stresses that it is the user that shall determine the suitability of a product for its end-use, and the user that assumes all liability in connection therewith.

Distribuito da:
 Mugnaini Group Srl - Via delle Cannelle Z.I. di Montranito - 55040 Stiava - Massarosa (LU)
 Tel. 0584 962344 - Fax 0584 940578 - info@mugnaini.it - www.mugnaini.it